

**INSTALLATION INSTRUCTIONS FOR  
DYNOMAX KIT: 19432**

2007 Chevrolet Silverado / GMC Sierra 2500HD, 3500 6.0L, 8.1L,  
All Models, 2/4 W.D., Single Exhaust



2701 N. Dettman Rd.  
Jackson, MI 49201

**DANGER WARNING:** SHOULD THE PURCHASER DECIDE TO INSTALL ANY EXHAUST PRODUCT AT HOME, BE WARNED THAT PASSENGER CAR OR LIGHT DUTY TRUCK/VAN "BUMPER" JACKS ARE INTENDED FOR EMERGENCY USE ONLY. THE USE OF FRAME CONTACT JACK STANDS IN CONJUNCTION WITH A FLOOR JACK AS MAIN SUPPORT IS HIGHLY RECOMMENDED TO MINIMIZE ACCIDENTAL DROPPING OF A VEHICLE DURING THE INSTALLATION PROCESS.

**NOTE:** Read all instructions before starting any work.

1. Remove the original equipment (O.E.) inlet pipe/muffler/tail pipe assembly from the vehicle. Lubricate the rubber isolators with WD-40, or a similar product, to aid in removal of the metal rod hangers.
2. Install DynoMax front exhaust pipe **52277**. Finger tighten the nuts on inlet flange studs.
3. If installing this system on a regular cab/long bed (133" W.B.) go to step 4. If installing on any other cab type please follow these directions. Install extension pipe **43319** after completing the following cut-off on the outlet O.D. sized end. For an extended cab/short bed (143.5") cut off 24". For a crew cab/short bed (153") cut off 14". For extended cab/long bed (157.5") cut off 9.5". For a crew cab/ long bed (167") no cut off is required on the 43319 pipe. Finger tighten a 4" U-Bolt clamp at the connection of 52277 and 43319.
4. Install DynoMax Ultra Flo Welded muffler **17557** with long dimension of the oval muffler in a vertical position and the inlet end connection at the bottom. See diagram on the back page.
5. If your truck is a regular cab/long bed (133"), an extended cab/long bed (157.5"), or a crew cab/long bed (167") install clamp-on rod hanger **36410** at the connection of the muffler inlet to the front exhaust pipe or extension pipe. Insert the rod into the rubber isolator on the RH frame. See the system diagram on the back page. If your truck is an extended cab/short bed (143.5") or a crew cab/short bed (153") install clamp-on rod hanger **36409** instead of and in place of the 36410

6. Also install clamp-on rod hanger **36408** onto pipe 43319 if your truck is a crew cab/short bed (153"), an extended cab/long bed (157.5") or a crew cab/long bed (167"). See the system diagram on the back page.
7. Install DynoMax tail pipe **55309**. Insert the metal rod hangers into the two rubber isolators on the chassis. Finger tighten the 4" clamp to the muffler outlet.
8. Install the stainless steel spout **36477** using the band clamp provided. Install the band clamp with the fasteners on top.
9. Beginning at the inlet end, align all the exhaust components and fully tighten all the clamps.
10. Please see system diagram on back page of these instructions.

**KIT CONTAINS:**

- (1) 17557 MUFFLER
- (1) 52277 INLET PIPE
- (1) 43319 EXTENSION PIPE
- (1) 55309 TAIL PIPE
- (1) 36477 TIP
- (1) 36408 CLAMP-ON HANGER
- (1) 36409 CLAMP-ON HANGER
- (1) 36410 CLAMP-ON HANGER
- (2) 4" U-BOLT CLAMPS
- (1) 4" BAND CLAMP
- (1) 702459 INSTRUCTION SHEET

**Cab Type — Wheel Base**

- Reg Cab, Long Bed - 133"
- Ext Cab, Short Bed - 143.5"
- Crew Cab, Short Bed - 153"
- Ext Cab, Long Bed - 157.5"
- Crew Cab, Long Bed - 167"

# 19432 SYSTEM DIAGRAM

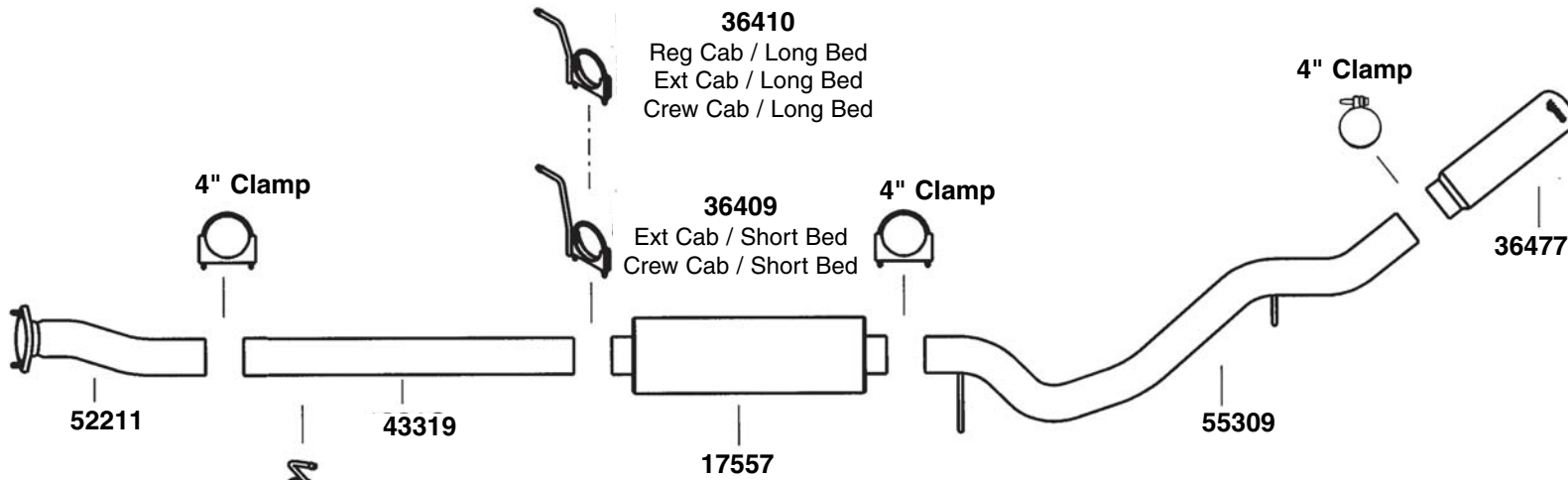

**36408**

Crew Cab / Short Bed  
Ext Cab / Long Bed  
Crew Cab / Long Bed

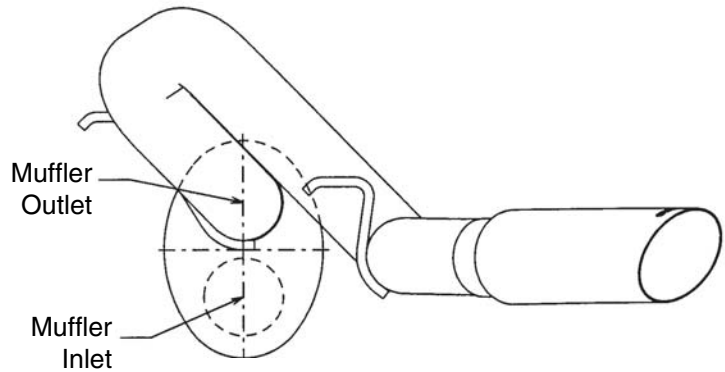

**VIEW LOOKING FROM REAR**